



TS 200

Indexeurs à came tambour



TS 200
Indexeurs à came tambour

TS 200



PA Ardennes Emeraude
Rue Henri Faure
08090 TOURNES
France
Tel.: +33 3 24 52 94 64
Fax.: +33 3 24 52 88 02
sopap@sopap.com
www.sopap.com

Cachet du distributeur:



TS 200

Indexeurs à came tambour

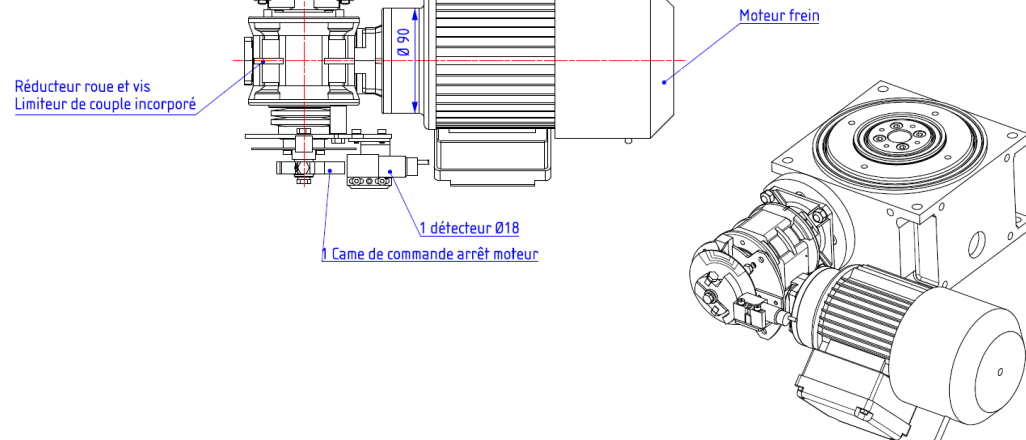
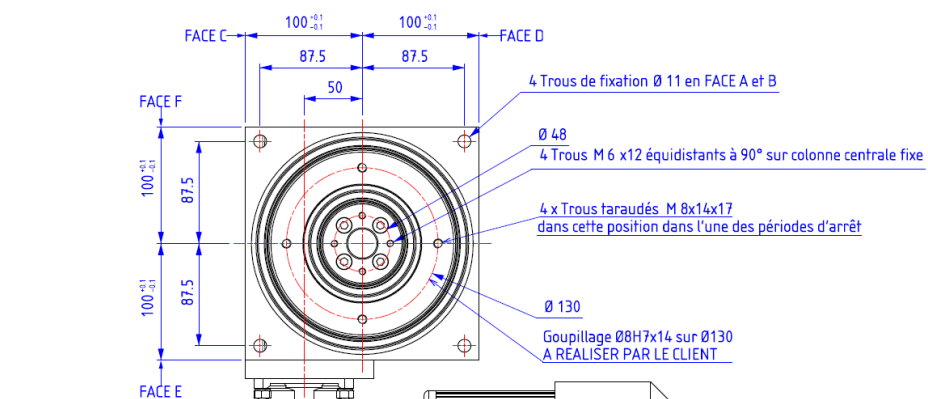
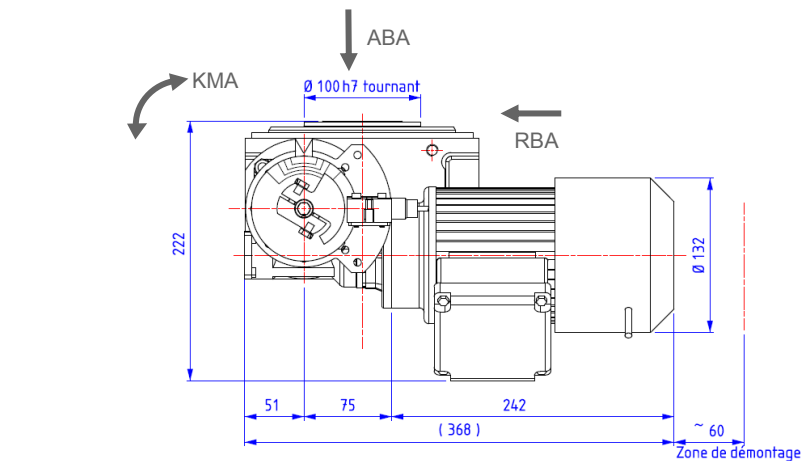

TS 200

TS 200

Indexeurs à came tambour

Caractéristiques techniques

TS	200	300	400
Répétabilité	± 0,01 mm sur Rs = 52,5 mm	± 0,01 mm sur Rs = 75 mm	± 0,01 mm sur Rs = 100 mm
Précision d'indexage	± 0,02 mm sur Rs = 52,5 mm	± 0,02 mm sur Rs = 75 mm	± 0,02 mm sur Rs = 100 mm
Charge axiale maxi admissible ABA	7 500 N	10 000 N	15 000 N
Couple de basculement maxi admissible KMA	250 Nm	300 Nm	1 000 Nm
Charge radiale maxi admissible RBA	2500 N	3500 N	5 000 N
Masse de la table motorisée	~ 25 kg	~ 50 kg	~ 80 kg

